

ECO Spot 35FC™ User Manual

Thank you for choosing an ECO Spot 35FC™ Gobo projector. This unit is equipped with a fan cooled 35W discharge light bulb, which delivers light output equivalent to a 250W halogen lamp.

Please read this manual before installing or operating this fixture, follow the safety precautions listed below and observe all warnings.



Package Contents

- ✓ Projector with power cord
- ✓ Test Gobo
- ✓ Spare gobo retaining ring and drive belt

Safety Information

- This product is not for household use, it presents risks of severe injury or death due to fire and burn hazards, electric shock, lamp explosion and falls.
- Place your fixture at a suitable place with good air flow.
- Keep flammable materials away from the fixture.
- Minimum distance to flammable material = 1 ft (0.3m).
- Minimum distance to illuminated surface = 3.3 ft (1.0m).
- Provide a minimum clearance of 4 in (10cm) around air vents.
- Use only genuine spare parts for part replacement.
- Do not look directly into the lamp; it can result in eye damage.
- Don't touch the hot surface during operation, use gloves if necessary.
- Always unplug the unit from the power mains before any service is done.
- Allow 20 minutes to cool down before servicing the unit.
- Replace Lamps only with the same type other lamps may cause damage.
- Light fixtures should be installed and maintained only by qualified personnel with experience in lighting equipment and general electrical experience.

Electrical Safety

- Disconnect the fixture from AC power before handling the fixture.
- Always ground (earth) the fixture electrically.
- Use only a power source that complies with local building and electrical codes and has both, overload and ground-fault protection.
- Do not use the fixture if the power cable or power plug is in any way damaged, defective or wet, or if they show signs of overheating.

Handling Instructions

- Before the initial start-up, please unpack and carefully check for damage caused during transportation.
- Place your fixture at a suitable place with good air flow.
- Make sure there are no flammable materials close to the lamp.
- After turning off the lamp, it will take 5-10 minutes to restart.
- Depending on the ambient temperature, the lamp may need up to 60 sec. to start.
- When suspending the fixture above ground level, verify that the structure can hold at least 10 times the weight of all installed devices.
- Verify that all external covers and rigging hardware are securely fastened and use an approved means of secondary attachment such as a safety cable.

Warranty

One Year from Date of Purchase

Contact

Globus New Media LLC
Tel 1-888-987-1112 or 1-408-416-4444
Fax 1-408-416-4445
www.globusnewmedia.com

Focusing

- Power up the projector by pressing the larger switch in the back.
- Turn on the gobo rotator with the smaller switch in the back and switch it off when the gobo projects in the desired position.
- Focus the projection by twisting the lens in and out until the image is well focused. When used for the first time, the lens will often need to be twisted outwards many rotations to reach the focusing point.

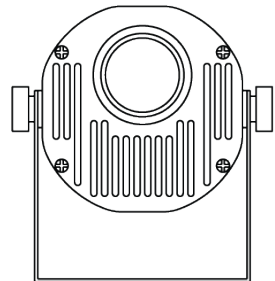

Gobo Rotator (model ES-35)

- Turn on and off the gobo rotator with the small switch on the back plate.
- There are no controls for rotating speed or direction.

Gobo Changer (model ES-LED35-C)

The gobo changer has four gobo slots. A timer continuously switches between the different gobos. It will always go the full sequence (slot 1,2,3,4,1,2,...), therefore all slots need to be populated with gobos. Turn on and off the gobo changer with the small switch on the back plate.

The interval timer can be set to changing intervals between 3-5-15-30-60-120 seconds. The interval time is selected by pushing the red button on the projector's back plate. Every push advances the interval to the next longer interval time (i.e. from 5 to 15 seconds). Push the button while the changer stands still. Once the longest time has been reached, it will start over at the shortest time. For showing only a single gobo w/o any changes, simply turn off the changer power switch on the back plate when the correct gobo shows. The unit has an additional static slot, which can be used as

- optional color overlay in conjunction with b/w gobos in the changer's gobo wheel.
- gobo color changer in conjunction with color filters in the changer's gobo wheel.

Gobo Replacement

Unplug the lamp before re-lamping the projector. Let the projector cool down for min. 20min. Use caution, the housing and light bulb may still be hot.

Unscrew the four thumbscrews to remove the front cover with the projection lens.

The gobo rotator with the gobo holder is now exposed.

Push the two pins of the gobo retaining ring together and pull out the retaining ring.

Carefully remove the old gobo and replace it with the new gobo.

If you have a glass gobo, place the most reflective side towards the light bulb.

Replace the retaining ring and make sure it evenly pushes the gobo all the way back.

Replace the front cover and adjust the focus.

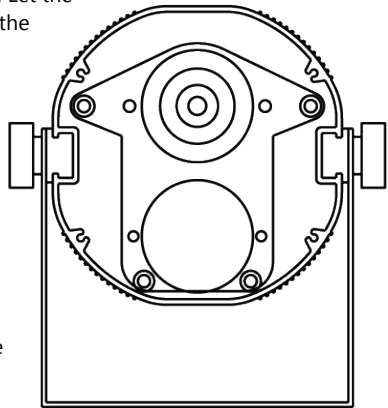

Lamp Replacement

Unplug the lamp before re-lamping the projector. Let the projector cool down for min. 20min. Use caution, the housing and light bulb may still be hot.

Unscrew the four thumbscrews to remove the front cover with the projection lens.

The gobo rotator with the gobo holder is now exposed.

Carefully pull out the gobo holder.

The lamp is now exposed. Remove it by twisting it counter clockwise and then pull it out of the socket. Reverse this procedure for the new lamp. Do not touch the glass of the lamp with your fingers.

Replace the gobo rotator and the front cover.

Specifications

Voltage (US Version)
90-130V, 50-60Hz, 0.38A, 41W
Power factor 0.98

International Version
200-240V, 50Hz, 0.2A, 41W

Ambient Operating Temperature

-13 to 104°F (-25 to 40°C)

Dimensions / Weight

Fixture Body: 10in x 5.25in (254mm x 133mm)

Yoke Base: 5.5in x 5.5in (140mm x 140mm)

Yoke Height: 6in (127mm)

Weight: 7lbs (3.1kg)

Gobo Dimensions

Metal or Glass Gobos and Dichroic filters
Outer Diameter (OD): 37.5mm (1.47 in)
Max. Image Diameter (ID): 25mm (1.0 in)
Max Thickness 4mm (0.16 in)

Replacement Lamp

35W HID MR16 Lamp with GU10 socket

Philips MASTERColour CDM-Rm Mini Elite35W/930 GX10 10D

Other product name: MC CDM-Rm Mini Elite 35W/930 GX10 10D

ILCOS code: MRS/UB-35/30/1A-H-GX10

Order Code: HID35Eco

Rated bulb life 12,000hrs

Expected bulb life 8,000hrs

Color temperature 3,000K

Luminous Intensity 18,000cd

Socket GX10

CRI 87-90

Lens Options

- Standard 20 degree (included)
- Narrow 10 degree
- Wide 25 degree

ECO Spot 35™ Photometrics

