

# ECO Spot 35FC™ User Manual

Thank you for choosing an ECO Spot 35FC™ Gobo projector. This unit is equipped with a fan cooled 35W discharge light bulb, which delivers light output equivalent to a 200W halogen lamp. Please read this manual before installing or operating this fixture, follow the safety precautions listed below and observe all warnings.



## Package Contents

- ✓ Projector with power cord
- ✓ Test Gobo
- ✓ Spare gobo retaining ring

## Safety Information

- This product is not for household use, it presents risks of severe injury or death due to fire and burn hazards, electric shock, lamp explosion and falls.
- Place your fixture at a suitable place with good air flow.
- Keep flammable materials away from the fixture.
- Minimum distance to flammable material = 1 ft (0.3m).
- Minimum distance to illuminated surface = 3.3 ft (1.0m).
- Provide a minimum clearance of 4 in (10cm) around air vents.
- Use only genuine spare parts for part replacement.
- Do not look directly into the lamp; it can result in eye damage.
- Don't touch the hot surface during operation, use gloves if necessary.
- Always unplug the unit from the power mains before any service is done.
- Allow 20 minutes to cool down before servicing the unit.
- Replace Lamps only with the same type other lamps may cause damage.
- Light fixtures should be installed and maintained only by qualified personnel with experience in lighting equipment and general electrical experience.

## Electrical Safety

- Disconnect the fixture from AC power before handling the fixture.
- Always ground (earth) the fixture electrically.
- Use only a power source that complies with local building and electrical codes and has both, overload and ground-fault protection.
- Do not use the fixture if the power cable or power plug is in any way damaged, defective or wet, or if they show signs of overheating.

### Handling Instructions

- Before the initial start-up, please unpack and carefully check for damage caused during transportation.
- Place your fixture at a suitable place with good air flow.
- Make sure there are no flammable materials close to the lamp.
- After turning off the lamp, it will take 5-10 minutes to restart.
- Depending on the ambient temperature, the lamp may need up to 60 sec. to start.
- When suspending the fixture above ground level, verify that the structure can hold at least 10 times the weight of all installed devices.
- Verify that all external covers and rigging hardware are securely fastened and use an approved means of secondary attachment such as a safety cable.

### Warranty

One Year from Date of Purchase

### Contact

Globus New Media LLC  
Tel 1-888-987-1112 or 1-408-416-4444  
Fax 1-408-416-4445  
[www.globusnewmedia.com](http://www.globusnewmedia.com)

### Focusing

Power up the projector and wait a few minutes for it to reach full brightness.

Twist the gobo cage until the artworks projects in the correct position.

Focus the projection by twisting the lens (not the complete cage) in and out until the image is well focused.

Replace the front cover to weather proof the fixture.

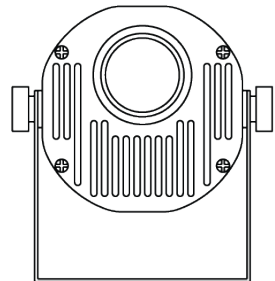

### Lens Options

- Standard 20 degree (included)
- Narrow 10 degree
- Wide 25 degree

### Gobo Replacement

Unplug the lamp before re-lamping the projector. Let the projector cool down for min. 20min. Use caution, the housing and light bulb may still be hot.

Unscrew the four thumbscrews to remove the front cover with the projection lens.

The gobo rotator with the gobo holder is now exposed.

Push the two pins of the gobo retaining ring together and pull out the retaining ring.

Carefully remove the old gobo and replace it with the new gobo.

If you have a glass gobo, place the most reflective side towards the light bulb.

Replace the retaining ring and make sure it evenly pushes the gobo all the way back.

Replace the front cover and adjust the focus.

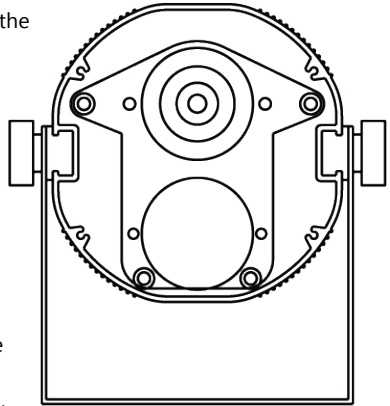

### Lamp Replacement

Unplug the lamp before re-lamping the projector. Let the projector cool down for min. 20min. Use caution, the housing and light bulb may still be hot.

Unscrew the four thumbscrews to remove the front cover with the projection lens.

The gobo rotator with the gobo holder is now exposed.

Carefully pull out the gobo holder.

The lamp is now exposed. Remove it by twisting it counter clockwise and then pull it out of the socket. Reverse this procedure for the new lamp. Do not touch the glass of the lamp with your fingers.

Replace the gobo rotator and the front cover.

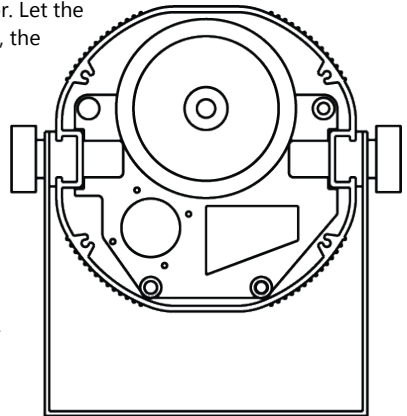

**Replacement Lamps**

**Specifications**

**Voltage (US Version)**

90-130V, 50-60Hz, 0.38A, 41W  
Power factor 0.98

**International Version**

200-240V, 50Hz, 0.2A, 41W

**Ambient Operating Temperature**

-13 to 104°F (-25 to 40°C)

**Dimensions**

11in x 5.25in (279mm x 133mm) without yoke.  
Weight 7lbs (3,175g)

**Gobo Dimensions**

Metal or Glass Gobos and Dichroic filters  
Outer Diameter (OD): 37.5mm (1.47 in)  
Max. Image Diameter (ID): 25mm (1.0 in)  
Max Thickness 4mm (0.16 in)

**35W HID MR16 Lamp with GU10 socket**

**Standard Bulb**

Very bright for max. light output  
HID MR16 Lamp GU10 35W,  
Rated bulb life 4,000hr  
Color temperature 6,000K  
Luminous Flux 2,200lm  
Order Code: HID35Eco

**Alternative Bulb**

Less bright for close range or dimmer environments  
GE HID MR16 Lamp GU10 35W  
Rated bulb life 10,000hr  
Color temperature 4,500K  
Luminous Flux 2,000lm  
Order code HID35EcoGE  
GE order code:  
CMH35/MR16/UVC/942/GX10/SP

**ECO Spot 35™ Photometrics**

