



AUREOL RECESSED BEAMSHAPER

The Aureol Recessed BeamShaper 1.0 brings to the architectural lighting market the use of projection and control of light in a fully recessed format. The unit allows the lighting effect to be the feature without the fitting being seen. By utilizing the BeamShaper lens body (same as the surface mounted BeamShaper) the recessed unit has the same level of high optical performance and ease of operation as the surface mounted unit. This makes the use of recessed and surface mounted unit on the same project easy for installation and maintenance as lamp type, projection patterns and focusing adjustment are the same.

Main Features

- Provides lighting effects without visual disruption to architectural spaces, 10 3/8" overall ceiling plate with 5" x 2 3/4" rounded aperture.
- Up to 45° tilt angle projection to wall and 360° rotation.
- Beam angle Zoom adjustment 26° to 50°.
- MR16 12v lamp (20w to 75w), industry standard.
- Unique mounting system allows easy angle and rotation for beam aiming with pan and tilt lock.
- Tamper and interference resistant for public areas. Recessed unit is less obvious.
- Integrated pattern mounting, no loose holder required. E size stainless steel or glass patterns are mounted inside the BeamShaper body.
- Four easily adjustable captive shaping shutters for beam shaping.
- Two integrated filter mounting slots – to carry colour filter 2" round or square (square cut is easier and cheaper than round) one of which can be up to 2/16" thick.
- Option of integrated or remote power supplies (remote 12v transformer provided by installer) or integrated electronic for compactness, ease of installation and efficiency or integrated electronic with on board dimmer, maximum 50W - 120V. Both options are dimmable by external architectural dimmer.

Note- The beam shaper uses our custom designed aspheric lens to minimise beam distortion and field curvature resulting in excellent pattern projection for a fixture of this type. The actual performance is dictated by the lamp used. For best results we ship the unit with the Osram 38° 50w Decostar lamp.

AUREOL BEAM SHAPER WITH OSRAM 38 DEGREE 50W DECOSTAR LAMP

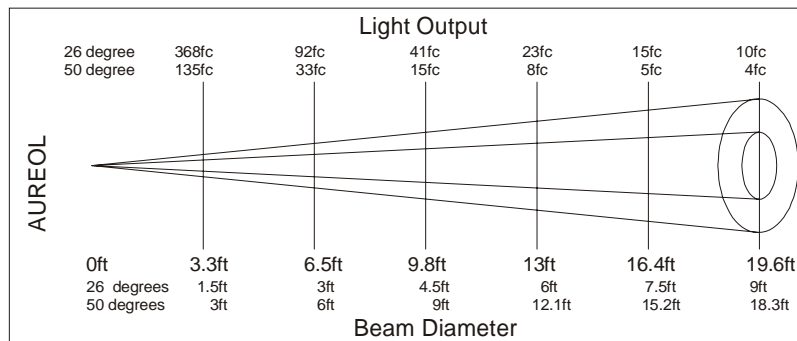

Specification codes and weights (includes lamp)

	Remote Transformer	Electronic Transformer	Electronic Transformer + on board dimmer
Recessed with ceiling plate	Code:ARLR## 5lb	Code:ARLRE##120 5lb 12oz	Code:ARLRED##120 5lb 12oz

Indicate finish by replacing ## with two digit code : 01=White / 02=Silver / 03=Black

Recessed BeamShaper 1.0 Configuration and mounting into ceiling



recessed housing

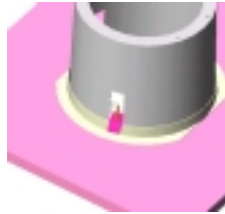

fixing into ceiling



access for focus



ceiling trim face
and re-lamping

Mounting: Recessed BeamShaper is mounted into the ceiling via the recessed housing. This allows the “lens tube” Shaper to tilt to 45° for projection of the shuttered beam or image onto a wall. The housing can be rotated 360° for aiming.

Key operating points of optical unit

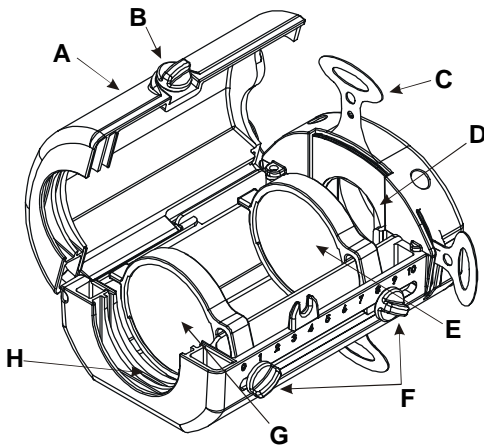

A: Beam Shaper Lid. This allows access to the lens compartment for inserting patterns or cleaning the lenses.

B: Lid Locking Knob. This locks the Beam Shaper lid closed.

C: Shutters. Four non-removable shutters are provided to allow you to mask portions of the beam, or to frame around pictures, etc.

D: Pattern Slot. This slot, just forward of the shutter plates, carries either glass patterns, which fit directly into the slot, or steel patterns which are inserted in front of the supplied ‘pattern spacer’ ring.

E: Rear Lens.

F: Lens Locking Knobs.

G: Front Lens.

H: Color filter and accessory slots.

Dimensions-

