

HIGH/LOW/OFF PIR OUTDOOR PHOTO/MOTION SENSOR IN IP66 ENCLOSURE FOR FLEXIBLE MOUNTING

| FSP-2X1B SERIES



FSP-2x1B



w/ Straight Nipple



w/ Drop Nipple



Product Overview

The FSP-2x1B is a family of passive infrared (PIR) outdoor sensors that raise or lower the electric lighting level to high, low or off based on motion and/or daylight contribution. Typically, once the sensor stops detecting movement and the time delay elapses, lights will first fade to low mode, and eventually switch off. When motion is detected, the sensor ramps the light level to high mode unless the daylight contribution is sufficient.

The integral photocell can also switch the lights on and off for dusk to dawn control, so that lighting remains on overnight even without motion detection.

The sensors control 0-10VDC or nondimming LED drivers or ballasts.

The low voltage FSP-201B may be used with dim-to-off drivers or ballasts.

Initial setup and subsequent sensor adjustments are made using a Wireless Handheld Configuration Tool (FSIR-100). This tool enables adjustment of sensor parameters including high/low mode, sensitivity, time delay, cut off and more.

The FSIR-100 can read current parameter settings, and stores up to six sensor parameter profiles to speed commissioning of multiple sensors.

The FSP-2x1B family is available in three configurations for mounting inside a fixture, to the outside of a fixture or enclosure via a 1/2" knockout, or to a pole.

*PEP designation applies to FSP-211B and FSP-221B only

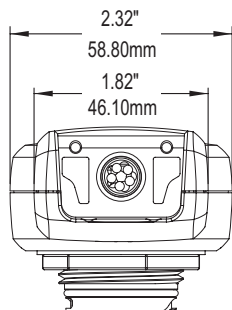
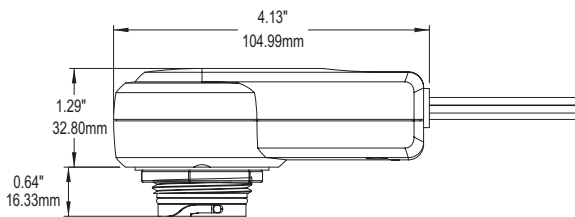

FSP-2x1B dimensions

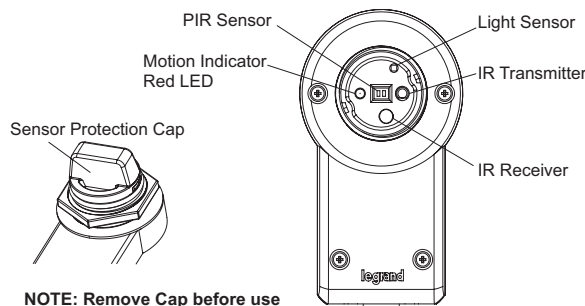

NOTE: Remove Cap before use

FSP-2x1B sensor module

Models

FSP-201B, 12-32VDC
Use with dim-to-off driver or ballast or with Wattstopper power pack

FSP-211B, 120/277VAC, 50/60Hz

FSP-221B, 100-347VAC (single phase) or 208/230/480VAC (phase-to-phase)

Specifications and Features

Load Ratings (FSP-211B, FSP-221B):
@ 120V 0-800W tungsten, ballast, LED driver; 1/6hp motor

@ 230-240V 0-300W ballast, LED driver
@ 277V 0-1200W ballast, LED driver; 1/6hp motor

@ 347/480V 0-1200W ballast, LED driver (FSP-221B only)

Current consumption (FSP-201B): 15 mA max.

0-10V sinking current: 50mA

Three interchangeable lenses for mounting between 8' and 40'

Remote setup and adjustment with handheld wireless configuration tool

Adjustable high and low modes (high: 0 to 10V, low: off, 0 to 9.8V)

Adjustable time delay (30 seconds, 1 to 30 minutes)

Adjustable cut off delay (none, 1 to 59 minutes, 1 to 5 hours)

Adjustable sensitivity/service mode (low, med, max; on-fix, off-fix)

Adjustable setpoints: hold off setpoint (none, 1 to 250 fc, auto); photocell on/off setpoint (1 to 250 fc)

Adjustable ramp and fade times (1 to 60 seconds)

Lead length: 36" (91.44cm), 30" (76.2cm) from nipple

Operating temperature: -40°F to +167°F (-40°C to +75°C)

Weight: FSP-201B, 4.9oz (140g); FSP-211B & FSP-221B, 6.7oz (190g)

UL and cUL listed (E101196)

IP66 rated

FSIR-100 is FCC Part 15 compliant

Five year warranty

Materials

Polycarbonate, flame retardant, UV resistant, impact resistant, recyclable
Meets materials restrictions of RoHS

Factory Defaults

High mode:	10V
Low mode:	1V
Time delay:	5 minutes
Cut off:	1 hour
Setpoint:	Disabled
Sensitivity:	Max
Ramp up time:	Disabled
Fade down time:	Disabled
Photocell On/Off:	Disabled

FSB-2x1B-x Dimensions, Side Views

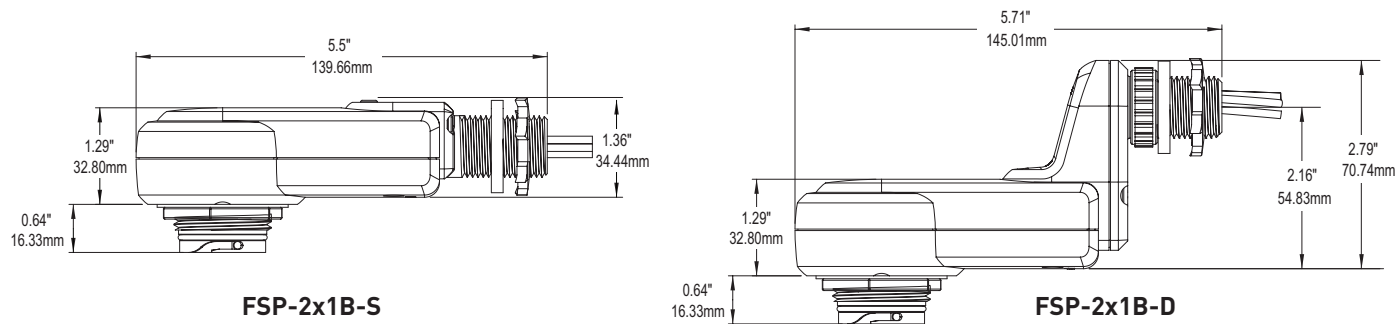

Coverage

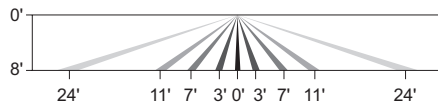
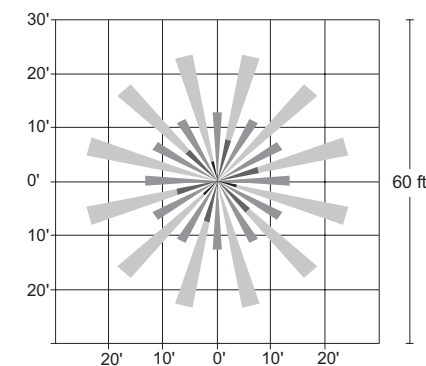

FSP-L2 top and side coverage patterns

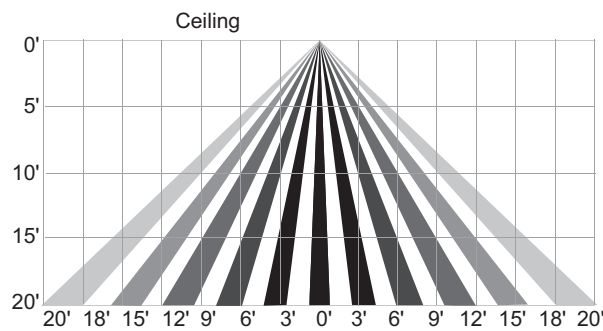
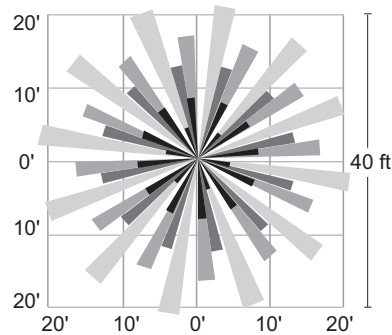

FSP-L3 top and side coverage patterns

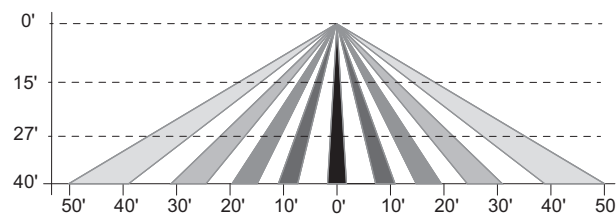
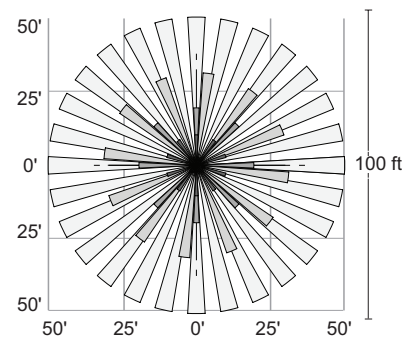

FSP-L7 top and side coverage patterns

Dimensions of Lens Options

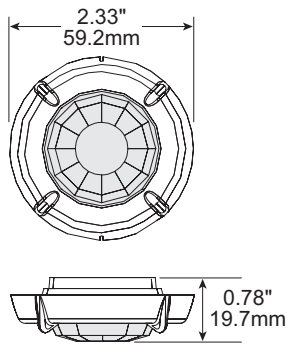

FSP-L2 dimensions

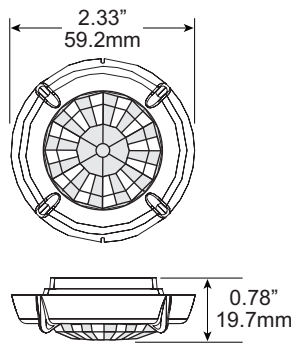

FSP-L3 dimensions

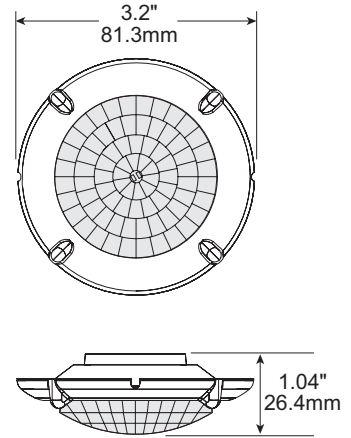

FSP-L7 dimensions

FSP-L2-S, FSP-L3-S, and FSP-L7-S Dimensions

The FSP-Lx-S models include a shroud, which blocks high-angle light coming from the fixture, to improve photocell performance. With the shroud attached, the dimensions for all three lenses are identical

FSP-L2-S and FSP-L3-S

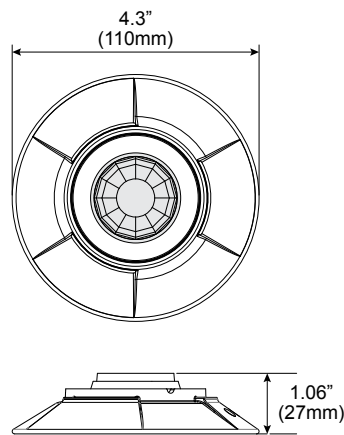

FSP-L7-S

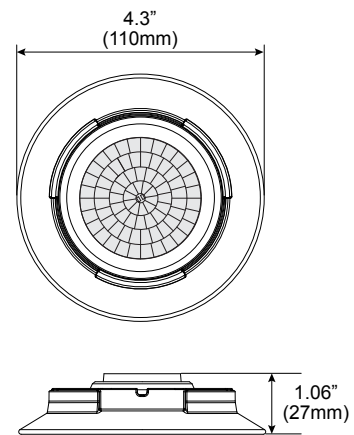

Installing the FSP-2x1B Sensor in Light Fixture

1. Determine an appropriate mounting location inside the light fixture. Allow a minimum distance of 0.2" (5.1mm) from the end of the sensor to the wall of the fixture.
2. Drill a 1.30" (33mm) diameter hole through the sheet metal in the bottom of the fixture.
3. Place the rubber gasket on the threaded collar, and install the sensor face down, parallel to the mounting surface. Ensure the rubber gasket touches the inside surface of the fixture. Install the tightening nut securely against the fixture to a torque of 25-30 in-lbs to ensure IP rating is maintained.
4. Align the locking features between the sensor and lens module and push the lens module forward until the O-ring seals firmly. Turn the lens module clockwise to lock in place.
5. Connect load, supply and control wires (see Figures 3 and 4).
6. Restore power from the circuit breaker.

NOTE: An optional collar can be installed in place of the tightening nut on the FSP-2x1B. This collar is included with the FSP-2x1B-S and FSP2x1B-D, as shown below.

Figure 1. Installing the FSP-2x1B in the light fixture

NOTE: The outside fixture wall thickness should be no greater than 0.125" (3.18mm) for optimal sensor mounting and security.

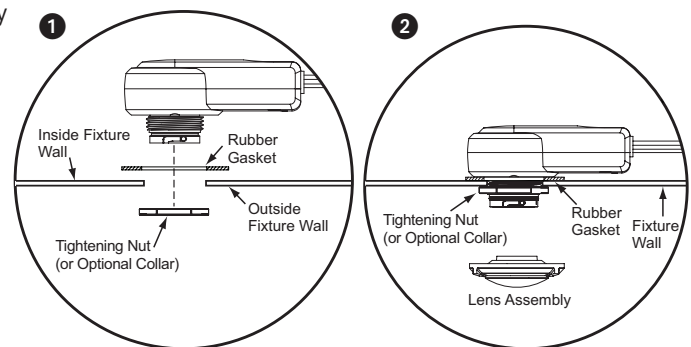

Installing the FSP-2x1B-S or FSP-2x1B-D To a Fixture or Pole

1. Determine an appropriate mounting location minimizing the electrical light contribution to the sensor's photocell.
2. Drill a 0.875" (22mm) diameter hole through the mounting surface, or mount to a 1/2" knockout.
3. Place the rubber gasket on the threaded collar, and install the sensor face down, parallel to the mounting surface. Ensure the rubber gasket touches the mounting surface. If needed, add the spacer between the sensor body and the rubber gasket to ensure a

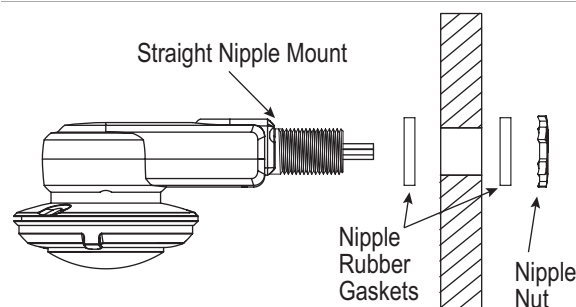

Figure 2. Installing the FSP-2x1B-S to the exterior of a fixture

NOTE: The outside fixture wall thickness should be no greater than 0.125" (3.18mm) for optimal sensor mounting and security.

4. Align the locking features between the sensor and lens module and push the lens module forward until the O-ring seals firmly. Turn the lens module clockwise to lock in place.
5. Connect load, supply and control wires (see Figures 3 and 4).
6. Restore power from the circuit breaker.

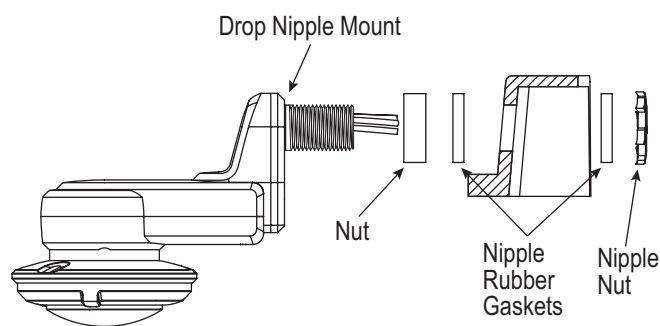

Figure 3. Installing the FSP-2x1B-D to a pole using the optional spacer

NOTE: The outside fixture wall thickness should be no greater than 0.125" (3.18mm) for optimal sensor mounting and security.

Adjustable Control Parameters

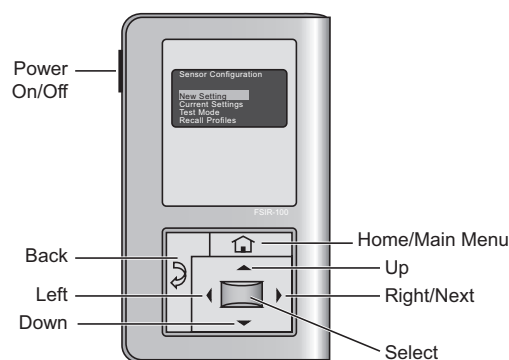
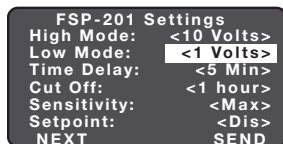
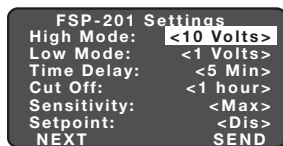
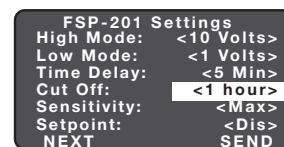
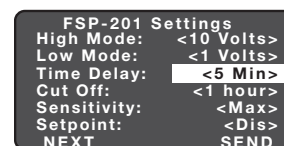

Figure 4. The FSIR-100 is a convenient handheld remote tool for setting up FSP-2x1B sensors. Adjustable settings can be changed as needed for specific applications.

1. High Mode: When the sensor detects motion the dimming control output ramps up to the selected HIGH light level (default is 10V).
2. Low Mode: After the sensor stops detecting motion and the time delay expires the dimming control output fades down to the selected LOW light level (default is 1V).



3. Time Delay: The selected time period that must elapse after the last time the sensor detects motion for the electric lights to fade to LOW mode (default is 5 minutes).
4. Cut Off: The time period that must elapse after the lights fade to LOW mode and the sensor detects no motion for the electric lights to turn OFF (default is 1 hour).



5. Sensitivity: The response of the PIR detector to motion within the sensor's coverage area (default is max).

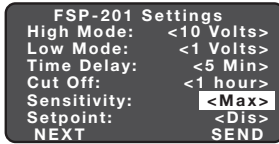

6. Setpoint: When enabled, the selectable ambient light level threshold that will hold the electric lights off or at LOW level when the sensor detects motion (default is disabled).

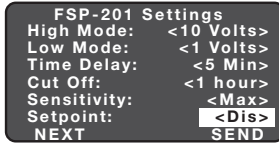

The Auto option invokes an automatic calibration procedure to establish an appropriate setpoint based upon the contribution of the electric light. As part of this procedure, the controlled load is turned on for two minutes to warm up the lamp, and then switched off and on eight times, terminating in an off state. After this process, a new setpoint value is automatically calculated.

7. Photocell On/Off: When enabled, the sensor will force the load OFF after the light level has exceeded the selected photocell setpoint for at least a minute. It will also force the load ON when the light level goes below the setpoint, even if no motion is detected (default if disabled).

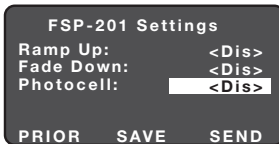

Once ON (initially at High), the load will dim to Low following the Time Delay, and to OFF following the Cut Off time. To ensure dusk to dawn control, Cut Off must be disabled.

The photocell On/Off setpoint is automatically set to maintain a deadband of at least 10 fc above the Hold Off Setpoint to prevent cycling if the two features are used together.

8. Ramp Up Time: Time period for light level to increase from LOW to HIGH (default is disabled; lights switch instantly).

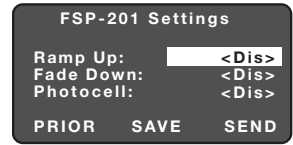

9. Fade Down Time: Time period for light level to decrease from HIGH to LOW (default is disabled; lights switch instantly).

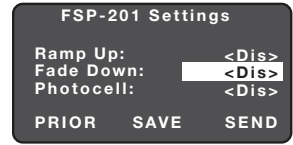

10. Lock Settings: Time delayed IR communication lock initiated from the FSIR-100 to prevent unauthorized changes of FSP-2x1B parameters until power is cycled to the sensor (default is disabled).

To lock settings, select Lock Delay, set a time, and press SEND to send the parameter change to the sensor. After the countdown, the sensor will no longer respond to the FSIR-100. If additional configuration is required, cycle the power to the FSP-2x1B sensor off and then back on. To disable the lock parameter after the power cycle, select Lock Delay, select Disable, and press SEND.

Wiring Diagrams for Low Voltage FSP-201B Sensors

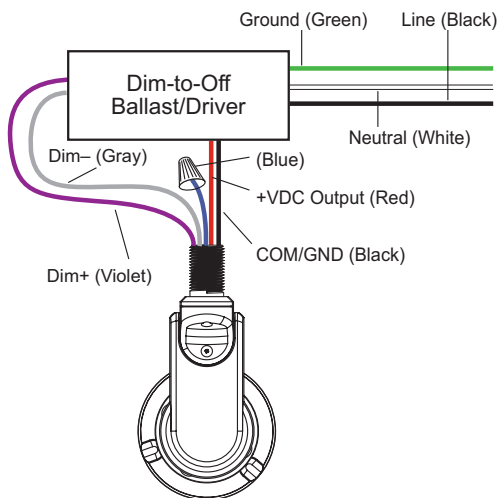

FSP-201B wiring with dim-to-off ballast or LED driver

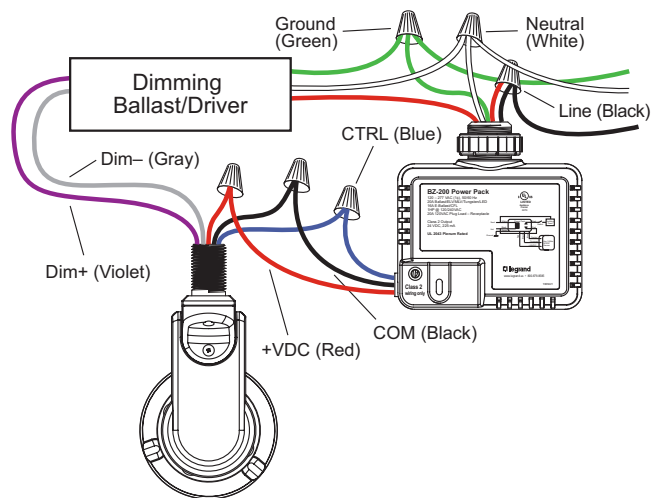

FSP-201B wiring with dimming ballast or LED driver and power pack for on/off control. If using a non-dimming ballast/driver, simply cap the gray and violet leads

Wiring Diagrams for Line Voltage FSP-211B and FSP-221B Sensors

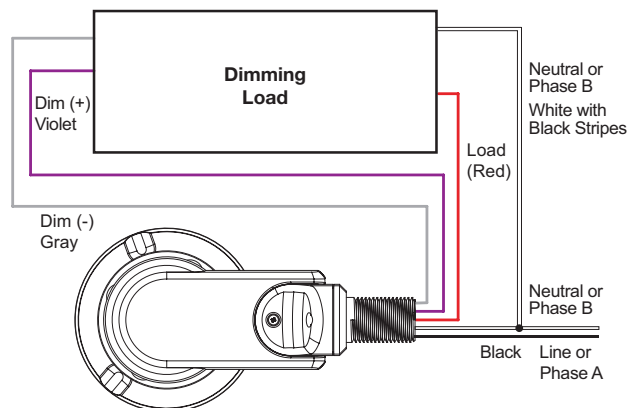
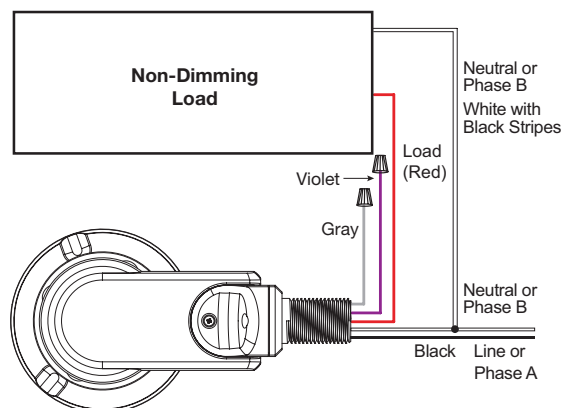
FSP-2x1-B wiring with dimming ballast or LED driver

FSP-2x1-B wiring with non-dimming load

Sequence of Operation

- Dimming:** When motion is detected within the sensor's coverage area, the sensor sends a signal to ramp the load up to the selectable High Mode level unless the ambient light level is higher than the selected setpoint. When no motion is detected for the duration of the time delay setting (factory preset at 5 minutes), the lights will go to the selectable Low Mode level based on the signal from the sensor. If desired, a cut off time delay (factory preset at 1 hour) will trigger to eventually turn the lights OFF.
- Non dimming:** When motion is detected within the sensor's coverage area, the sensor sends a signal to turn the load ON unless the ambient light level is higher than the selected setpoint. When no motion is detected for the duration of the time delay setting (factory preset at 5 minutes), the lights will go OFF based on the signal from the sensor.
- Dusk to dawn control:** When photocell on/off is enabled, and the ambient light falls below the photocell setpoint, the sensor ramps the load up to the selectable High Mode level. If no motion is detected for the duration of the time delay setting (factory preset at 5 minutes), the lights will go to the selectable Low Mode level. If the cut off time delay is disabled, the load will remain on, at High or Low level, based on motion detection, until the ambient light increases above the photocell setpoint.

Ordering Information

Catalog #	Master Pack Details					Inner Pack Details				
	Master Pack Quantity	Case dimensions (inches)			Weight (pounds)	Inner Pack Quantity	Case dimensions (inches)			Weight (pounds)
		Length	Width	Height			Length	Width	Height	
FSP-201B	40	19.2	12.7	11.6	18.3	20	18.8	12.3	5.3	8.3
FSP-211B	40	22.2	15.9	16.1	21	20	21.7	15.4	7.6	10.5
FSP-221B	40	22.2	15.9	16.1	21	20	21.7	15.4	7.6	10.5
FSP-201B-S-L2 or L3	40	22.2	15.9	16.1	23.2	20	21.7	15.4	7.6	10.5
FSP-201B-S-L7	40	22.2	15.9	16.1	24.9	20	21.7	15.4	7.6	11.4
FSP-201B-D-L2 or L3	40	22.2	15.9	16.1	24.9	20	21.7	15.4	7.6	11.4
FSP-201B-D-L7	40	22.2	15.9	16.1	26.7	20	21.7	15.4	7.6	12.2
FSP-211B-S-L2 or L3	40	22.2	15.9	16.1	27.6	20	21.7	15.4	7.6	12.8
FSP-211B-S-L7	40	22.2	15.9	16.1	28.9	20	21.7	15.4	7.6	13.6
FSP-211B-D-L2 or L3	40	22.2	15.9	16.1	28.9	20	21.7	15.4	7.6	13.6
FSP-211B-D-L7	40	22.2	15.9	16.1	31.5	20	21.7	15.4	7.6	14.4
FSP-221B-S-L2 or L3	40	22.2	15.9	16.1	27.6	20	21.7	15.4	7.6	12.8
FSP-221B-S-L7	40	22.2	15.9	16.1	28.9	20	21.7	15.4	7.6	13.6
FSP-221B-D-L2 or L3	40	22.2	15.9	16.1	28.9	20	21.7	15.4	7.6	13.6
FSP-221B-D-L7	40	22.2	15.9	16.1	31.5	20	21.7	15.4	7.6	14.4

Catalog #	Color	Description	Voltage
<input type="checkbox"/> FSP-201B	White	Fixture mount PIR sensor, low voltage, no nipple or lens	12-32VDC
<input type="checkbox"/> FSP-211B	White	Fixture mount PIR sensor, line voltage, no nipple or lens	120/277VAC; 50/60Hz
<input type="checkbox"/> FSP-221B	White	Fixture mount PIR sensor, extended voltage, no nipple or lens	100-347VAC or 208/230/480VAC
<input type="checkbox"/> FSIR-100	Black	Remote Handheld Configuration Tool	Three 1.5V AAA batteries (included)
<input type="checkbox"/> FSP-L2	White	360° lens, maximum coverage 48' diameter from 8' height	
<input type="checkbox"/> FSP-L2-B	Black		
<input type="checkbox"/> FSP-L2-BR	Brown		
<input type="checkbox"/> FSP-L2-G	Gray		
<input type="checkbox"/> FSP-L2-S	White	360° lens, maximum coverage 48' diameter from 8' height, with shroud; Minimizes high-angle light contribution to photocell	
<input type="checkbox"/> FSP-L3	White	360° lens, maximum coverage 40' diameter from 20' height	
<input type="checkbox"/> FSP-L3-B	Black		
<input type="checkbox"/> FSP-L3-BR	Brown		
<input type="checkbox"/> FSP-L3-G	Gray		
<input type="checkbox"/> FSP-L3-S	White	360° lens, maximum coverage 40' diameter from 20' height, with shroud; Minimizes high-angle light contribution to photocell	
<input type="checkbox"/> FSP-L7	White	360° lens, maximum coverage 100' diameter from 40' height	
<input type="checkbox"/> FSP-L7-B	Black		
<input type="checkbox"/> FSP-L7-BR	Brown		
<input type="checkbox"/> FSP-L7-G	Gray		
<input type="checkbox"/> FSP-L7-S	White	360° lens, maximum coverage 100' diameter from 40' height, with shroud; Minimizes high-angle light contribution to photocell	
<input type="checkbox"/> FSP-C1-W	White	Aesthetic collar to transition from fixture housing to lens, for use with FSP-L2 and FSP-L3 lenses (Optional for models above. Included with -D and -S models ordered below) Note: Not used with lenses that include shroud	
<input type="checkbox"/> FSP-C1-B	Black		
<input type="checkbox"/> FSP-C1-BR	Brown		
<input type="checkbox"/> FSP-C1-G	Gray		
<input type="checkbox"/> FSP-C2-W	White	Aesthetic collar to transition from fixture housing to lens, for use with FSP-L7 lens (Optional for models above. Included with -D and -S models ordered below) Note: Not used with lens that includes shroud	
<input type="checkbox"/> FSP-C2-B	Black		
<input type="checkbox"/> FSP-C2-BR	Brown		
<input type="checkbox"/> FSP-C2-G	Gray		

Note: Unless used with a driver or ballast with a low voltage power supply, the FSP-201B requires a Wattstopper power pack (ordered separately) to operate. FSP-Lx series lens required for operation; order lens separately if ordering models listed above. FSIR-100 required for configuration; order separately.

To order fully assembled -S or -D model sensor, select one option from each column below and combine part numbers (as example, FSP-201B-S-L2-B) Information supplied above is subject to change. Harmonization code 8537109030. Country of origin: China.

Pole or Box Mount Sensor Voltage	Nipple Configuration	Lens Option	Color
<input type="checkbox"/> FSP-201B, 12-32VDC sensor	<input type="checkbox"/> S, Straight Nipple	<input type="checkbox"/> L2, 360° lens, max coverage 48' diameter from 8' height	<input type="checkbox"/> B, Black
<input type="checkbox"/> FSP-211B, 120/277VAC sensor	<input type="checkbox"/> D, Drop Nipple	<input type="checkbox"/> L3, 360° lens, max coverage 40' diameter from 20' height	<input type="checkbox"/> BR, Brown
<input type="checkbox"/> FSP-221B, 100-347VAC (single phase) or 208/230/480VAC sensor (phase to phase)		<input type="checkbox"/> L7, 360° lens, max coverage 100' diameter from 40' height	<input type="checkbox"/> G, Grey <input type="checkbox"/> W, White